

SILICON NPN TRANSISTOR

- SGS-THOMSON PREFERRED SALESTYPE
- NPN TRANSISTOR

DESCRIPTION

The MJE3440 is a NPN silicon epitaxial planar transistors in SOT-32 plastic package. It is designed for use in consumer and industrial line-operated applications.

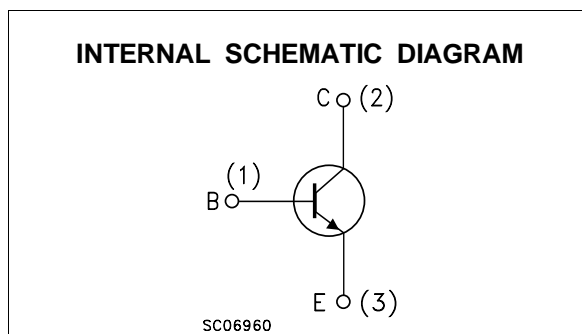
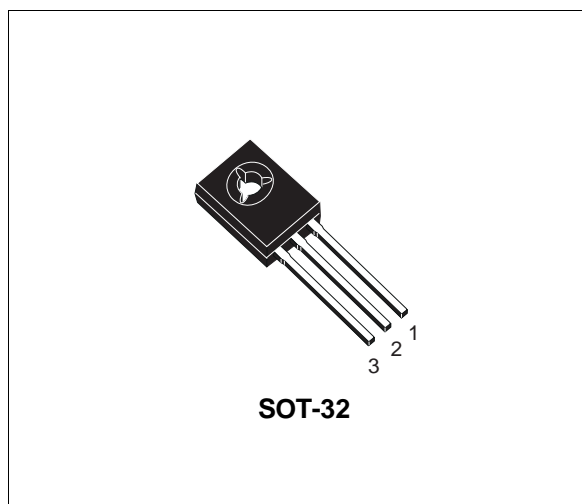

ABSOLUTE MAXIMUM RATINGS

Symbol	Parameter	Value	Unit
V_{CBO}	Collector-Base Voltage ($I_E = 0$)	350	V
V_{CEO}	Collector-Emitter Voltage ($I_B = 0$)	250	V
V_{EBO}	Emitter-Base Voltage ($I_C = 0$)	5	V
I_C	Collector Current	0.3	A
I_B	Base Current	0.15	A
P_{tot}	Total Power Dissipation at $T_{case} \leq 25^\circ C$	15	W
T_{stg}	Storage Temperature	-65 to +150	$^\circ C$
T_j	Max. Operating Junction Temperature	150	$^\circ C$

MJE3440

THERMAL DATA

R _{thj-case}	Thermal Resistance Junction-case	Max	8.33	°C/W
-----------------------	----------------------------------	-----	------	------

ELECTRICAL CHARACTERISTICS (T_{case} = 25 °C unless otherwise specified)

Symbol	Parameter	Test Conditions	Min.	Typ.	Max.	Unit
I _{CBO}	Collector Cut-off Current (I _E = 0)	V _{CB} = 250 V			20	μA
I _{CEV}	Collector Cut-off Current (V _{BE} = -1.5V)	V _{CE} = 300 V			500	μA
I _{CEO}	Collector Cut-off Current (I _B = 0)	V _{CE} = 200 V			50	μA
I _{EBO}	Emitter Cut-off Current (I _C = 0)	V _{EB} = 5 V			20	μA
V _{CE(sat)*}	Collector-Emitter Saturation Voltage	I _C = 50 mA I _B = 4 mA			0.5	V
V _{BE(sat)*}	Base-Emitter Saturation Voltage	I _C = 50 mA I _B = 4 mA			0.3	V
V _{BE*}	Base-Emitter Voltage	I _C = 50 mA V _{CE} = 10 V			0.8	V
h _{FE*}	DC Current Gain	I _C = 2 mA V _{CE} = 10 V I _C = 20 mA V _{CE} = 10 V	30 50		200	
h _{fe}	Small Signal Current Gain	I _C = 5 mA V _{CE} = 10 V f = 1 KHz	25			
f _T	Transistor Frequency	I _C = 10 mA V _{CE} = 10 V f = 5 MHz	15			MHz
C _{CB0*}	Collector-Base Capacitance	V _{CB} = 10 V I _E = 0 f = 1 MHz			10	pF

* Pulsed: Pulse duration = 300μs, duty cycle ≤ 1.5 %

Safe Operating Area

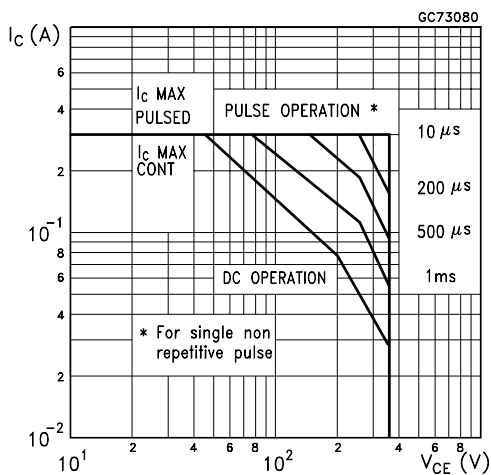

Derating Curve

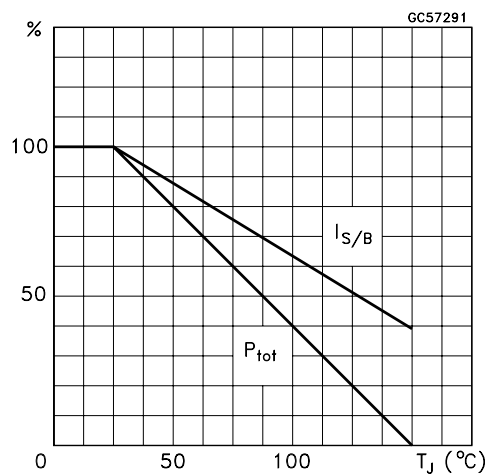

DC Current Gain

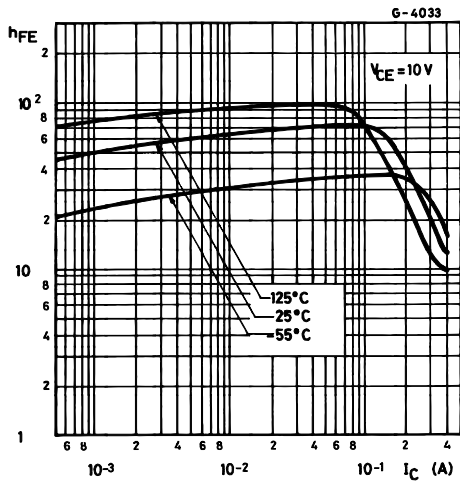

Collector-emitter Saturation Voltage

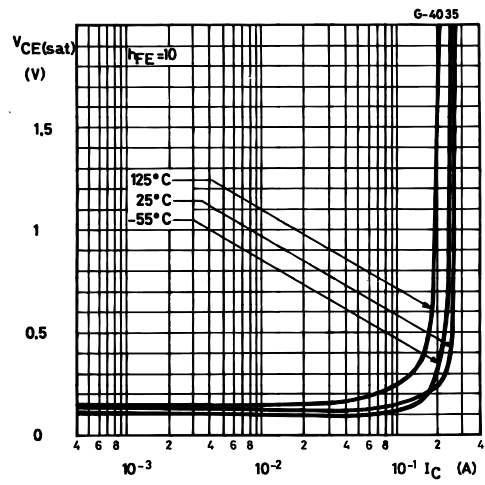

Base-emitter Voltage

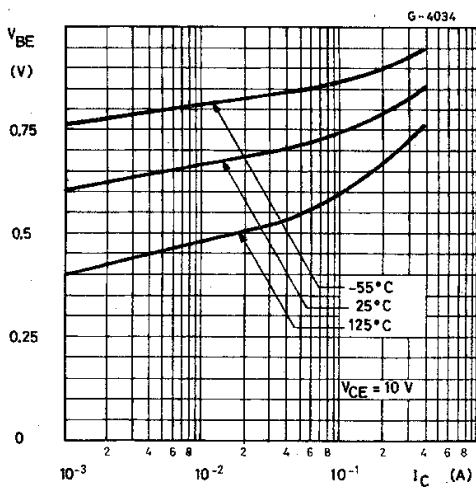

Transition Frequency

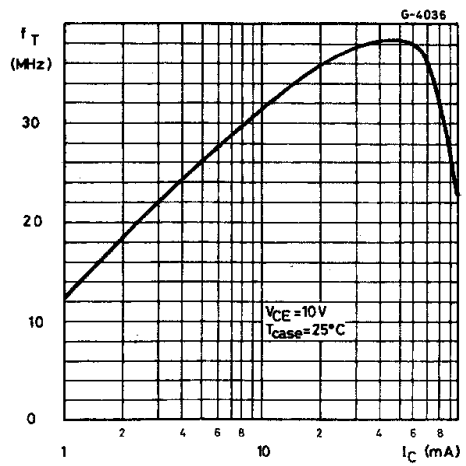

SOT-32 (TO-126) MECHANICAL DATA

DIM.	mm			inch		
	MIN.	TYP.	MAX.	MIN.	TYP.	MAX.
A	7.4		7.8	0.291		0.307
B	10.5		10.8	0.413		0.445
b	0.7		0.9	0.028		0.035
b1	0.49		0.75	0.019		0.030
C	2.4		2.7	0.040		0.106
c1	1.0		1.3	0.039		0.050
D	15.4		16.0	0.606		0.629
e		2.2			0.087	
e3	4.15		4.65	0.163		0.183
F		3.8			0.150	
G	3		3.2	0.118		0.126
H			2.54			0.100
H2		2.15			0.084	

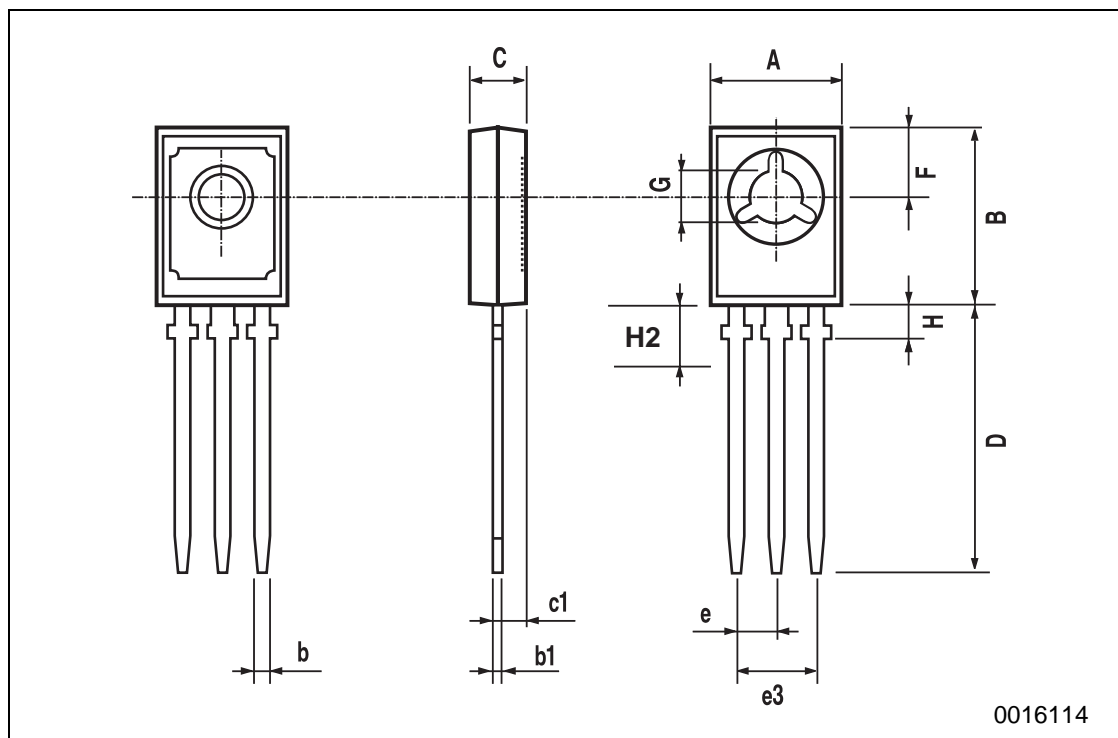

Information furnished is believed to be accurate and reliable. However, SGS-THOMSON Microelectronics assumes no responsibility for the consequences of use of such information nor for any infringement of patents or other rights of third parties which may result from its use. No license is granted by implication or otherwise under any patent or patent rights of SGS-THOMSON Microelectronics. Specifications mentioned in this publication are subject to change without notice. This publication supersedes and replaces all information previously supplied. SGS-THOMSON Microelectronics products are not authorized for use as critical components in life support devices or systems without express written approval of SGS-THOMSON Microelectronics.

© 1997 SGS-THOMSON Microelectronics - Printed in Italy - All Rights Reserved

SGS-THOMSON Microelectronics GROUP OF COMPANIES
Australia - Brazil - Canada - China - France - Germany - Hong Kong - Italy - Japan - Korea - Malaysia - Malta - Morocco - The Netherlands -
Singapore - Spain - Sweden - Switzerland - Taiwan - Thailand - United Kingdom - U.S.A
...

This datasheet has been download from:

www.datasheetcatalog.com

Datasheets for electronics components.