

MegaDrum32 Digital Board

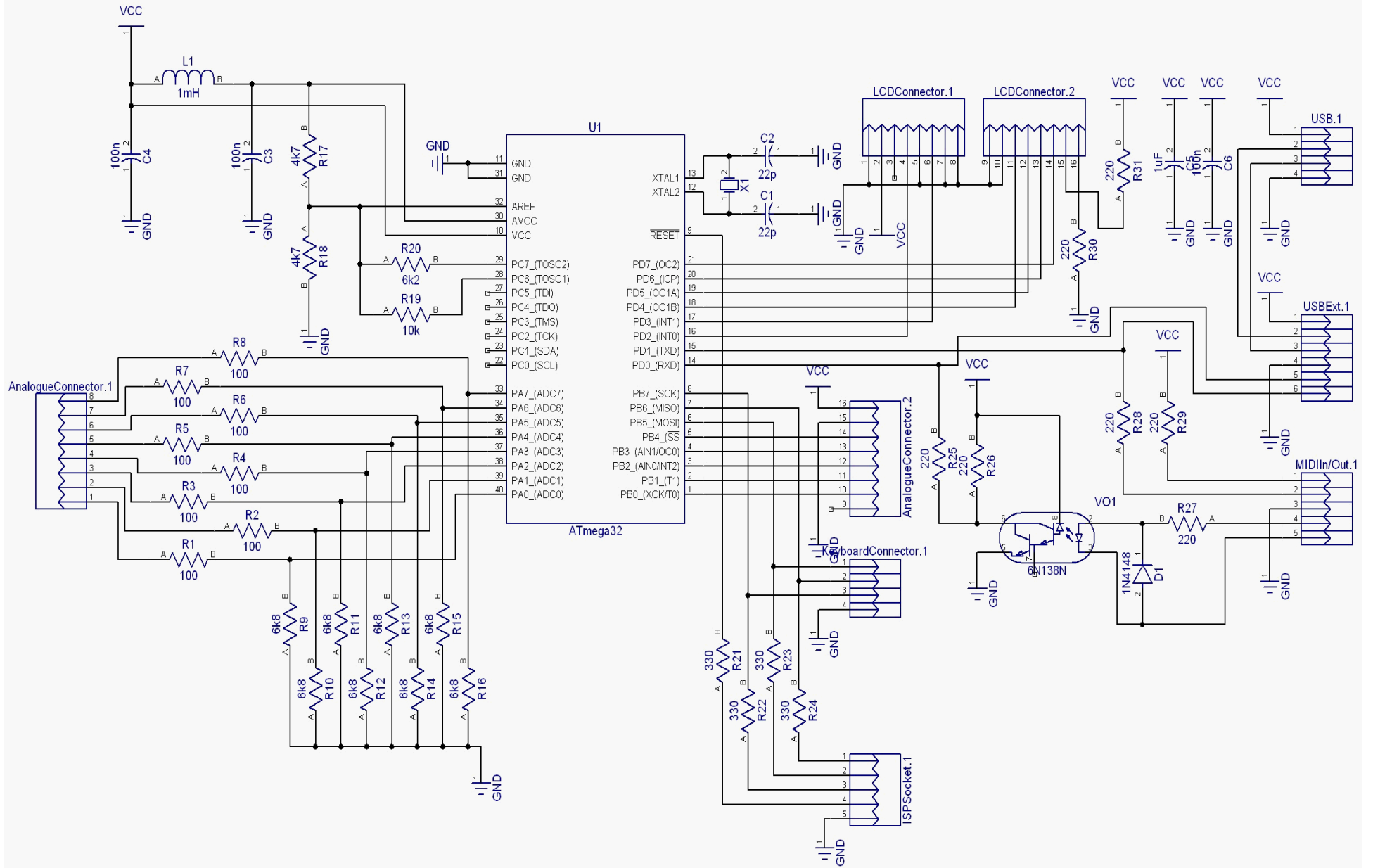

MegaDrum8 Digital Board

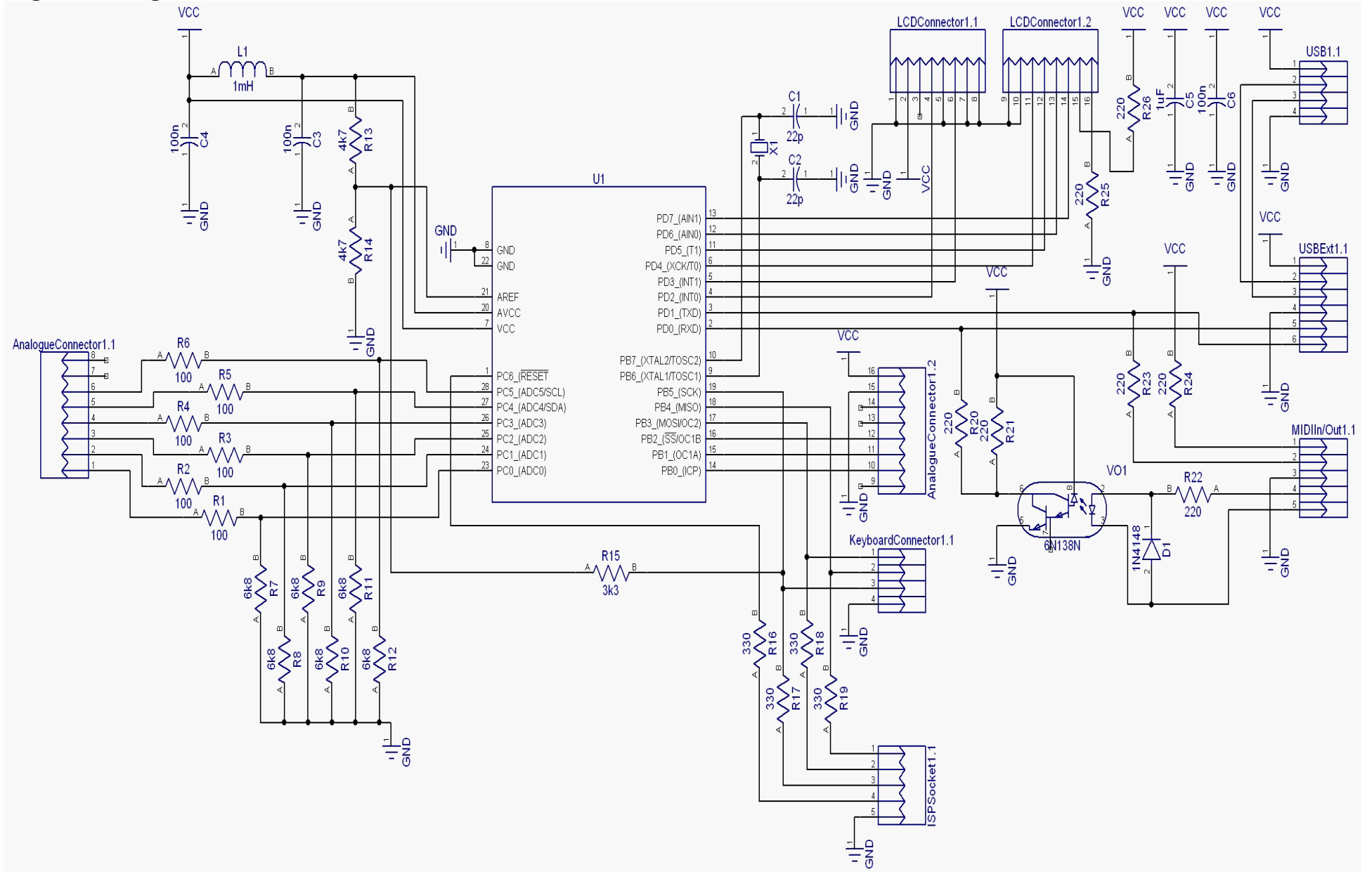

MegaDrum LCD, Keys and MIDI I/O

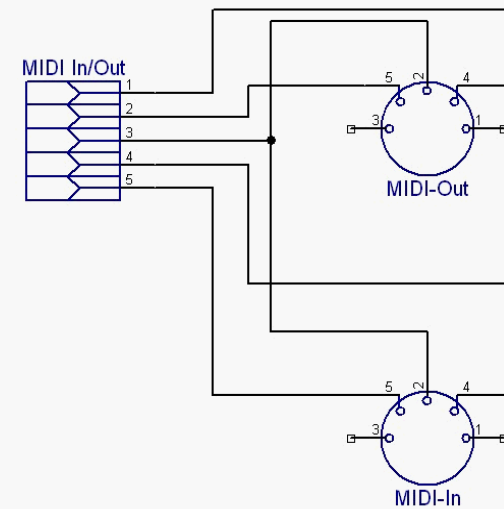
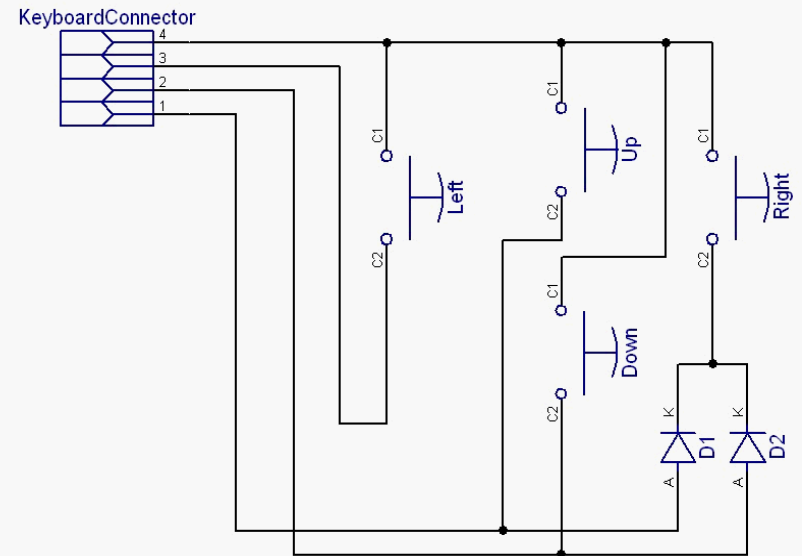
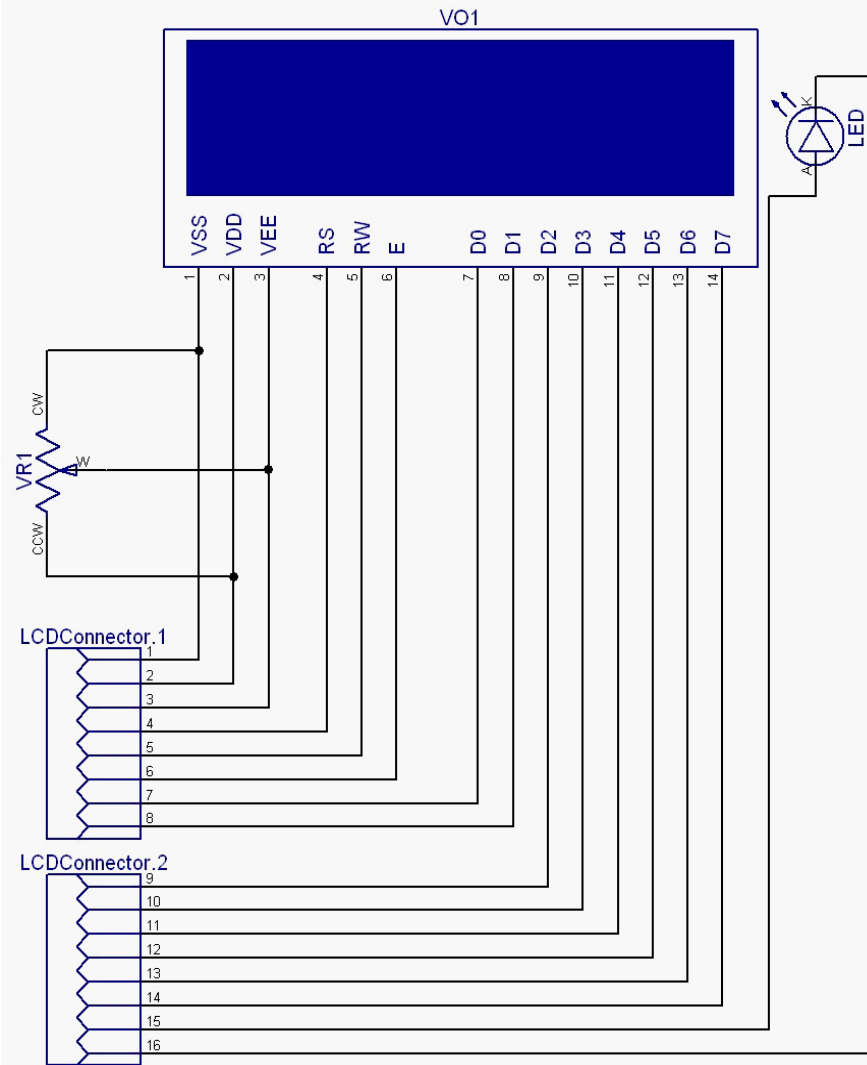

MegaDrum Analogue Board

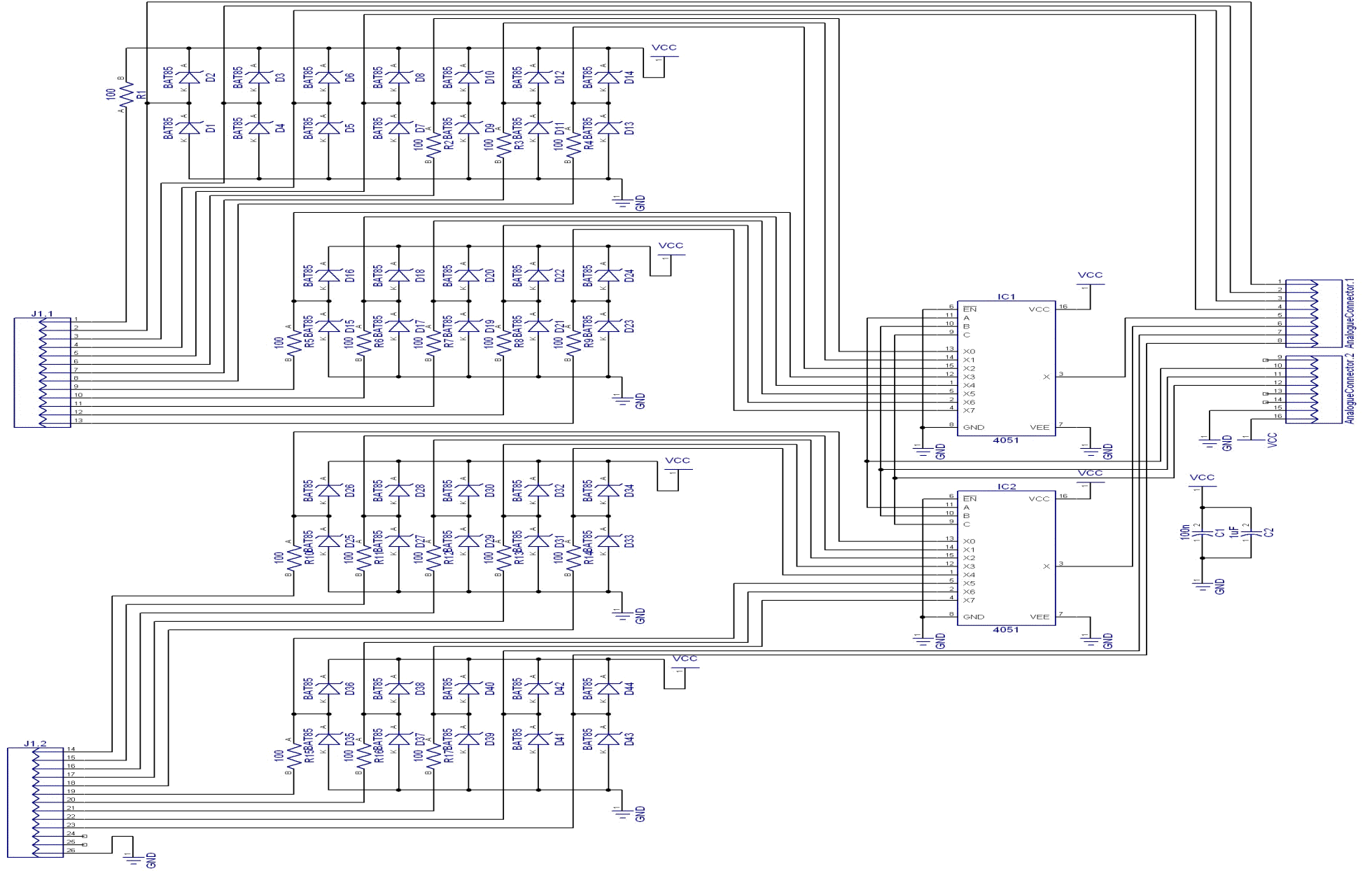

MegaDrum Input Cable

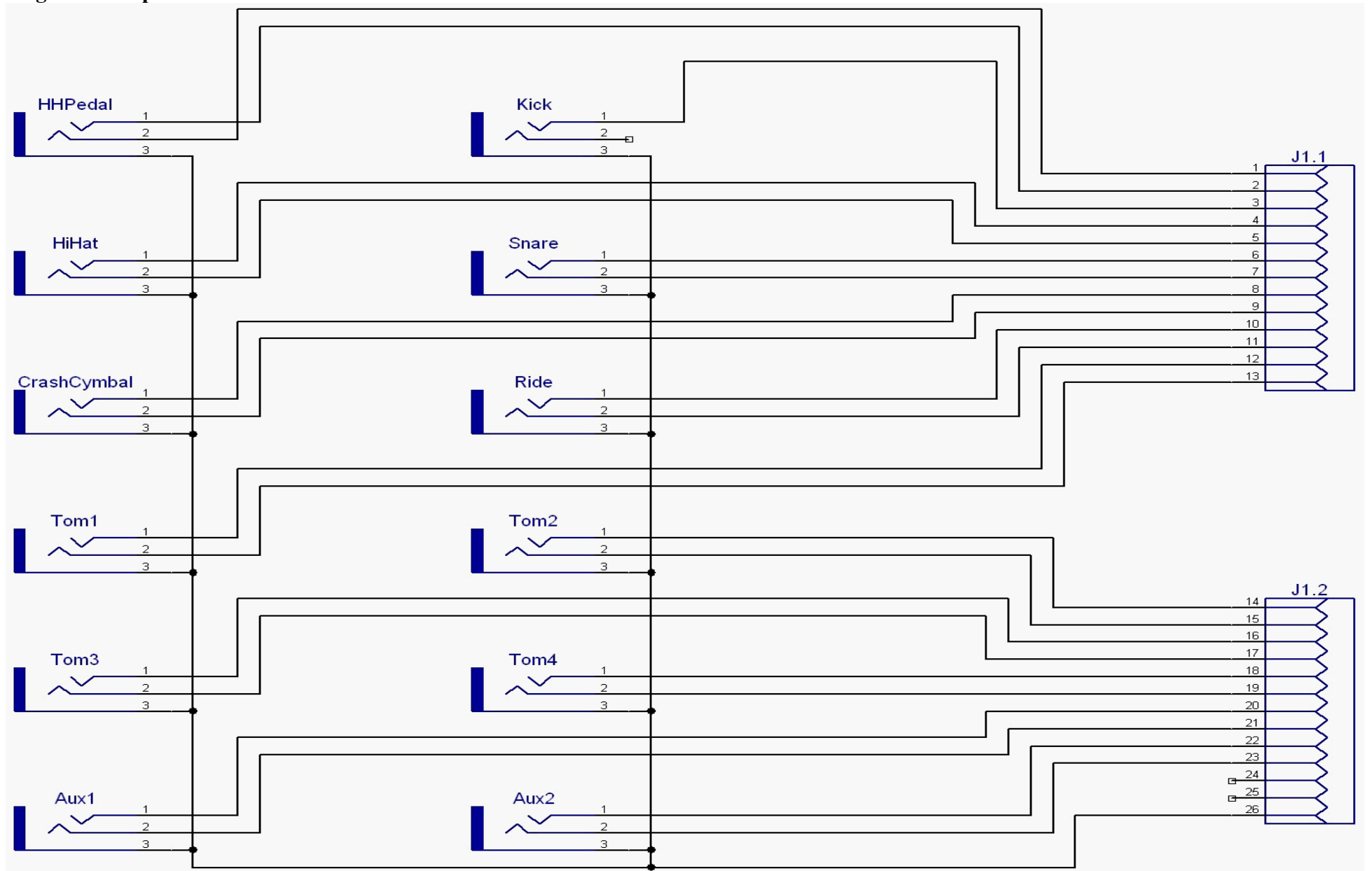

PIC18F2550 USB Real MIDI I/O

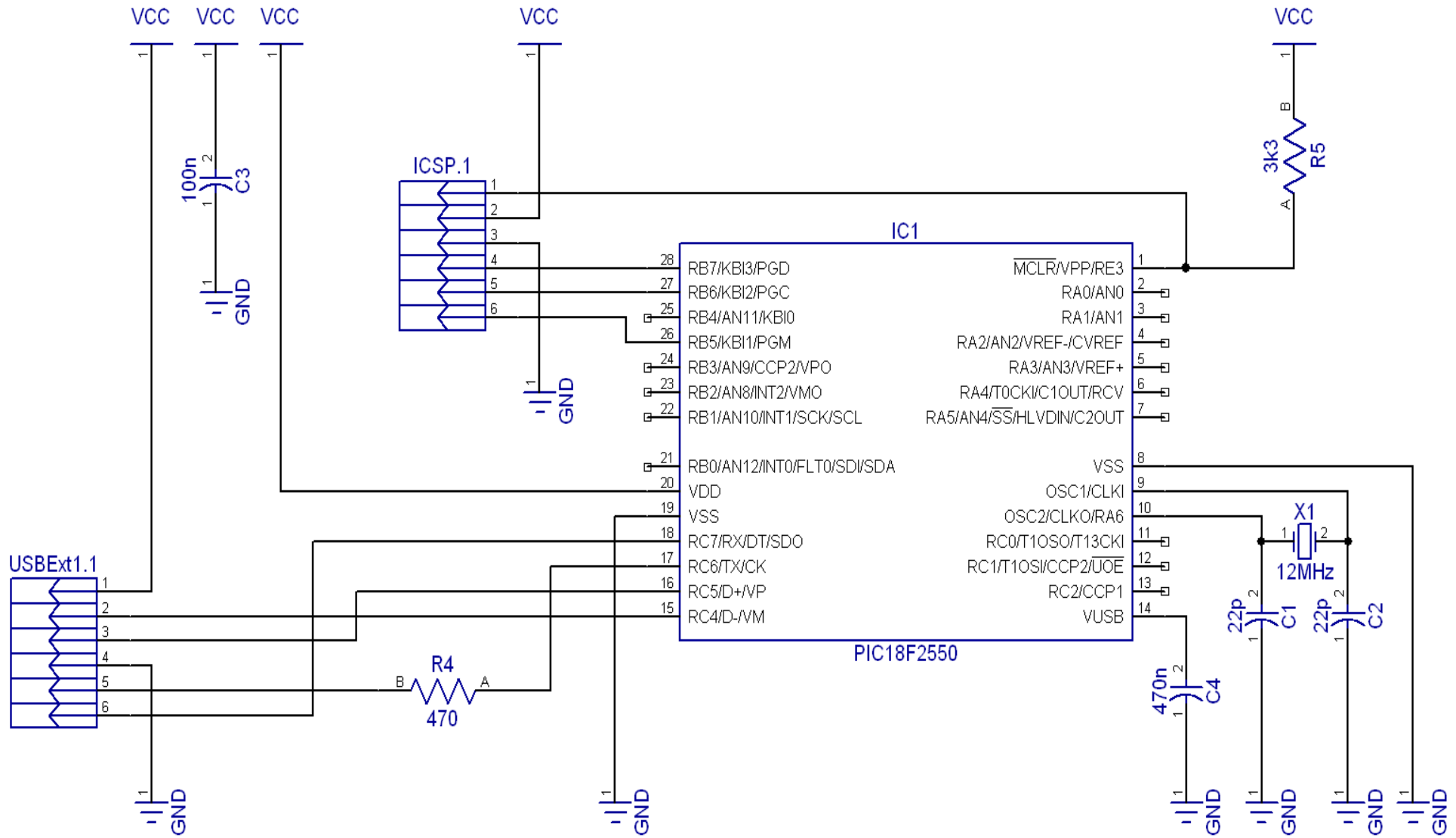

FT232 USB MIDI over Serial I/O

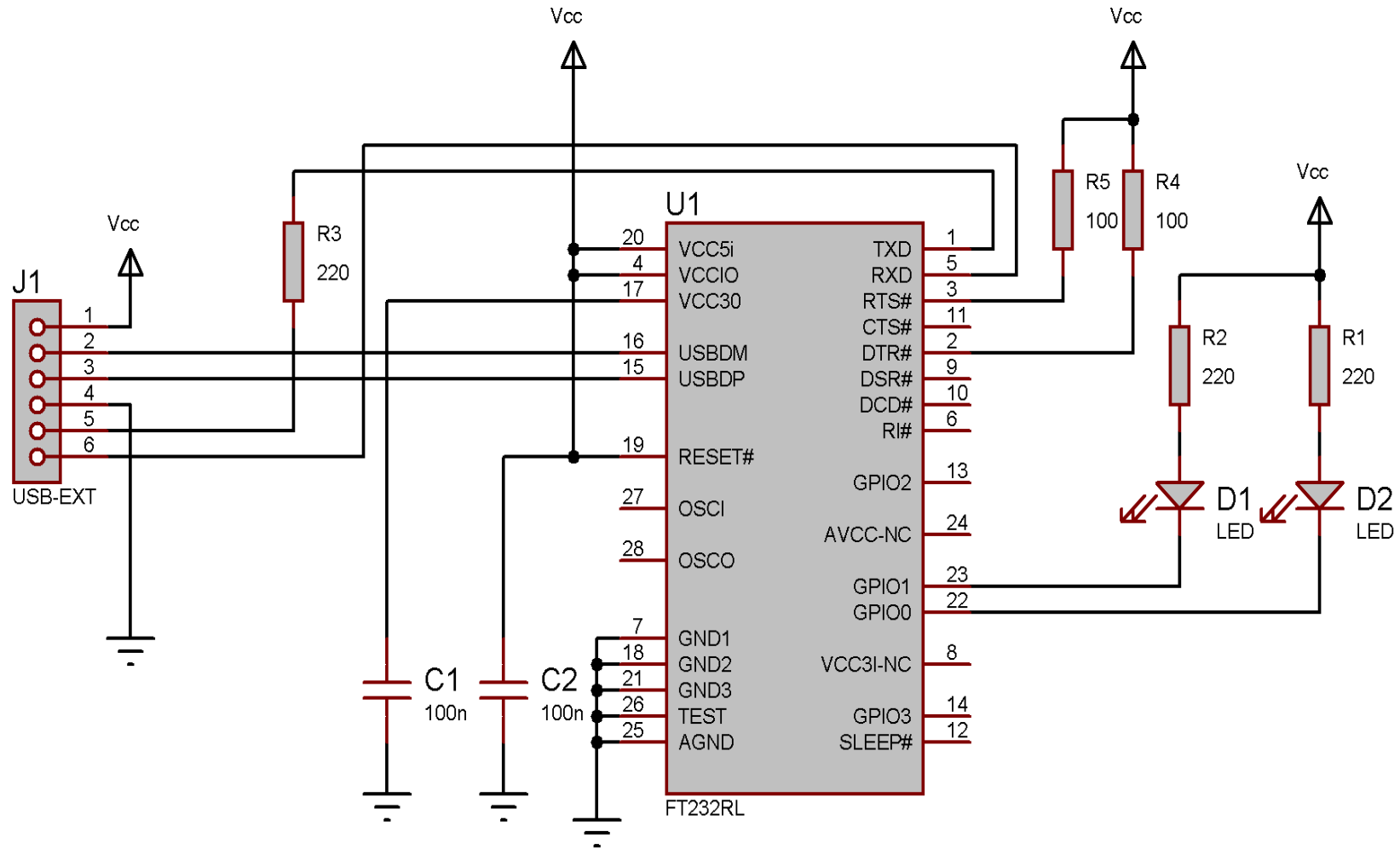

AVR-CDC USB MIDI over Serial I/O

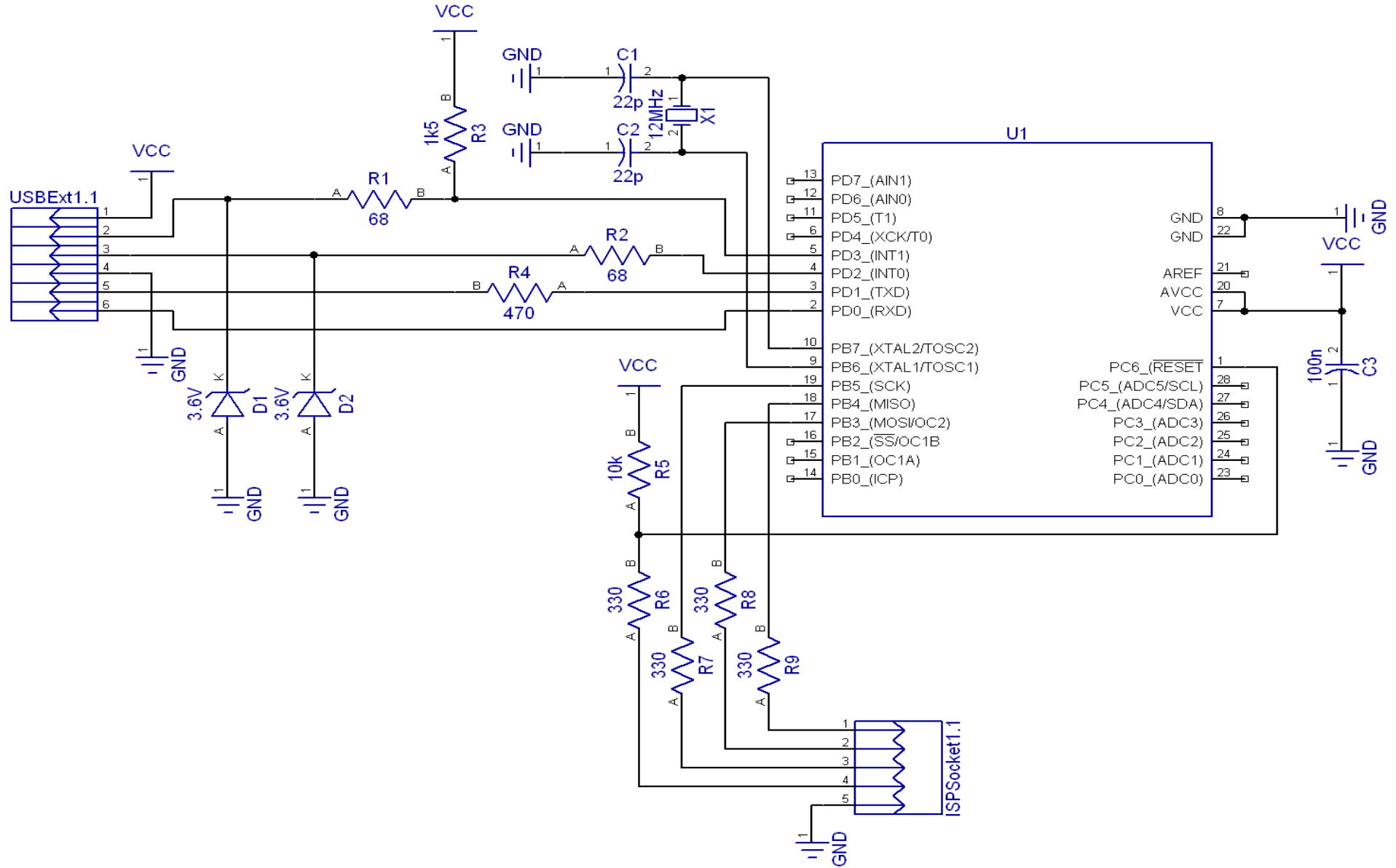

ISP Programming cable for Atmega

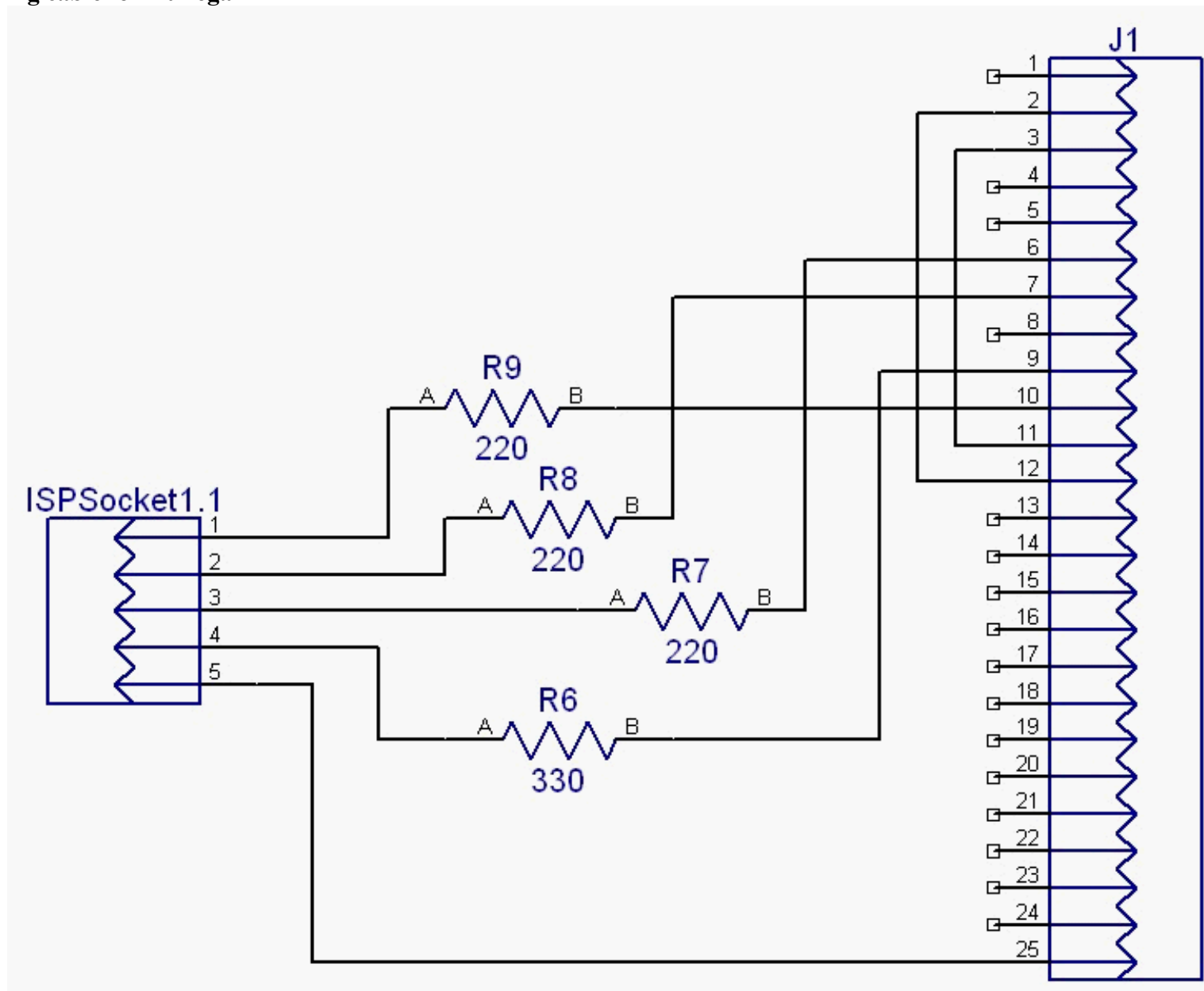

ICSP Programming cable for PIC18F2550

